

THIS DRAWING IS UNPUBLISHED. RELEASED FOR PUBLICATION
 © COPYRIGHT 19 BY TYCO ELECTRONICS CORPORATION. ALL RIGHTS RESERVED.

LOC	DIST	REVISIONS					
CE	00	P	LTR	DESCRIPTION	DATE	DWN	APVD
		M		REVISE PER ECR-05-005983	26JUL2005	BB	DK

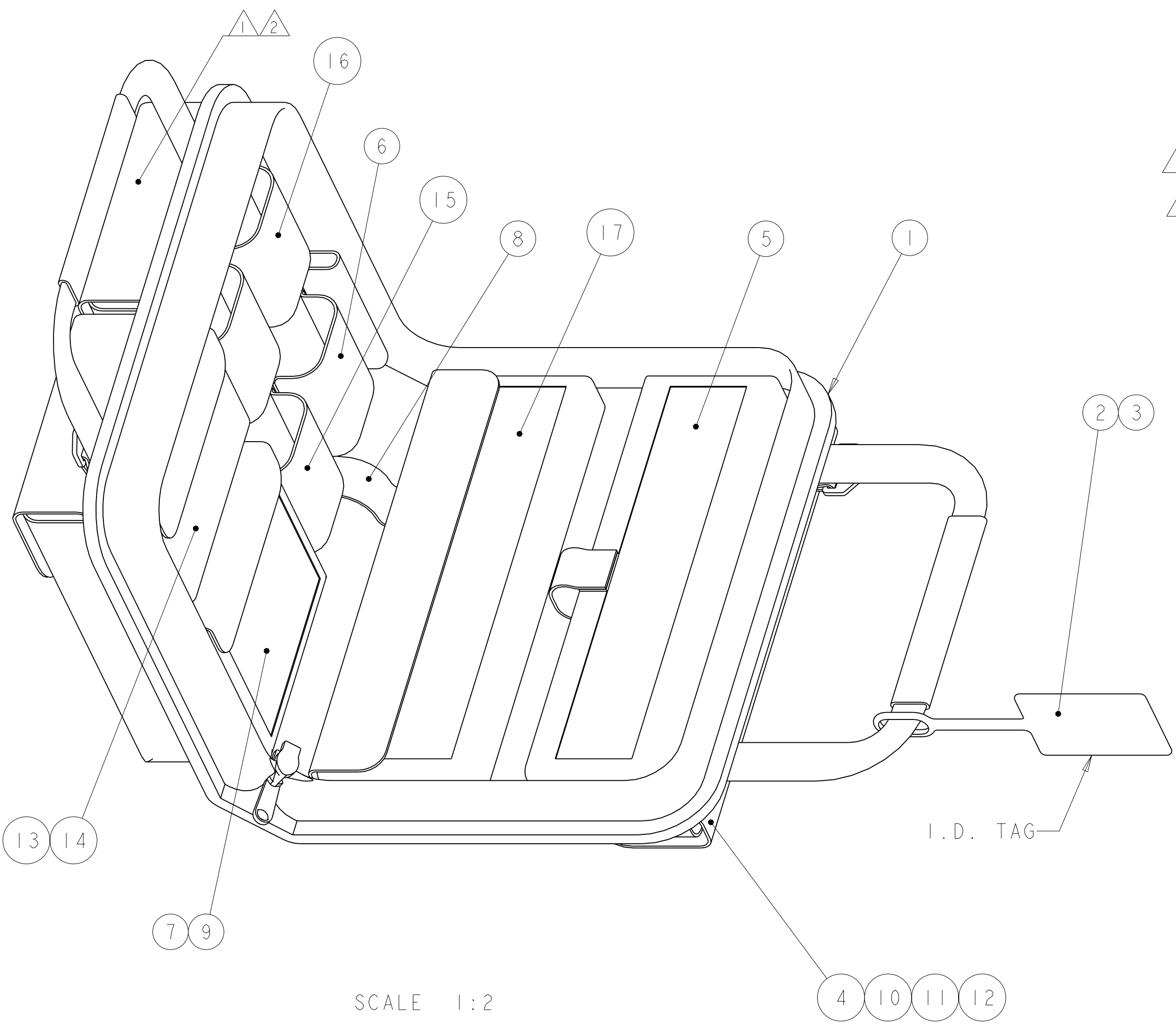

△ AMP INSTRUCTION SHEETS AND MANUFACTURERS' INSTRUCTION SHEETS.
 △ SHOULDER STRAP, OPTIONAL.

SCALE 1:2

1	-	MICROSCOPE WITH 10X OBJECTIVE	1754767-1	17
1	1	MICRO STRIP TOOL, (.008)	492109-2	16
1	1	COMBINATION STRIP TOOL	1754708-1	15
1	1	POLISHING BUSHING, METAL	503787-1	14
5	5	POLISHING BUSHING, PLASTIC	502631-1	13
10	10	LAPPING FILM, 5um	228433-8	12
10	10	LAPPING FILM, 0.3um	228433-5	11
1	1	POLISH PAD	504584-1	10
1	1	CABLE PREP TEMPLATE	503694-1	9
1	1	SCISSORS	-	8
1	1	UNIVERSAL CLEAVE TOOL	503705-1	7
1	1	CABLE STRIPPER	1278531-1	6
1	1	HAND TOOL WITH DIESET	492782-1	5
1	1	POLISH PLATE	501197-1	4
1	-	CASE LABEL	-	3
-	1	CASE LABEL	-	2
1	1	CARRYING CASE	-	1
-2	-1	DESCRIPTION	PART NUMBER	ITEM

<small>THIS DRAWING IS A CONTROLLED DOCUMENT FOR TYCO ELECTRONICS CORPORATION. IT IS SUBJECT TO CHANGE AND THE CONTROLLING ENGINEERING ORGANIZATION SHOULD BE CONTACTED FOR THE LATEST REVISION.</small>		DWN B. BRIGGS 26JUL2005 CHR D. KIRSCH 26JUL2005 APVD S. BUCHTER 26JUL2005	AMP AMP Incorporated Harrisburg, PA 17105-3608
DIMENSIONS: mm	TOLERANCES UNLESS OTHERWISE SPECIFIED: 0 PLC ± 1 PLC ± 2 PLC ± 3 PLC ± 4 PLC ± ANGLES ± FINISH -	NAME TERMINATION KIT, AMP LightCrimp SC	SIZE A2 CAGE CODE 00779 DRAWING NO C=503706 RESTRICTED TO -
MATERIAL -	FINISH -	WEIGHT -	CUSTOMER DRAWING SCALE 1:2 SHEET 1 OF 1 REV M